



Diana-Inserted



Diana-Single Grille



Diana-Surface mounted

**Application:**

The Diana Spot Light Series has the features of simple and beautiful appearance, compact structure, lightweight and easy to use, soft light, safe use and high efficiency; It is a kind of LED luminaire suitable for indoor lighting which is directly mounted on the ordinary mounting surface. Used in shopping malls, offices, airport terminals, train stations, subways, etc. .Different scenes have different local lighting designs, and you can enjoy life in more detail.

**Feature & Benefits:**

- 1.Optional: Inserted、 Surface mounted
- 2.Modular design, 3appearance options
- 3.High light transmission polyester convex lens to reduce light loss.
- 4.No Flicker and Buzzing, comfortable for your eyes, provides a comfortable, stress-free atmosphere
- 5.CRI90 High ability of revealing the colors of various objects faithfully and protect your eyes, allowing you to enjoy the most realistic objects' color. provides a comfortable, stress-free atmosphere.

**Application place:**

Residential home/Living room/Bedroom/Apartments/Hotel/Restaurant.

**Available Sizes:**

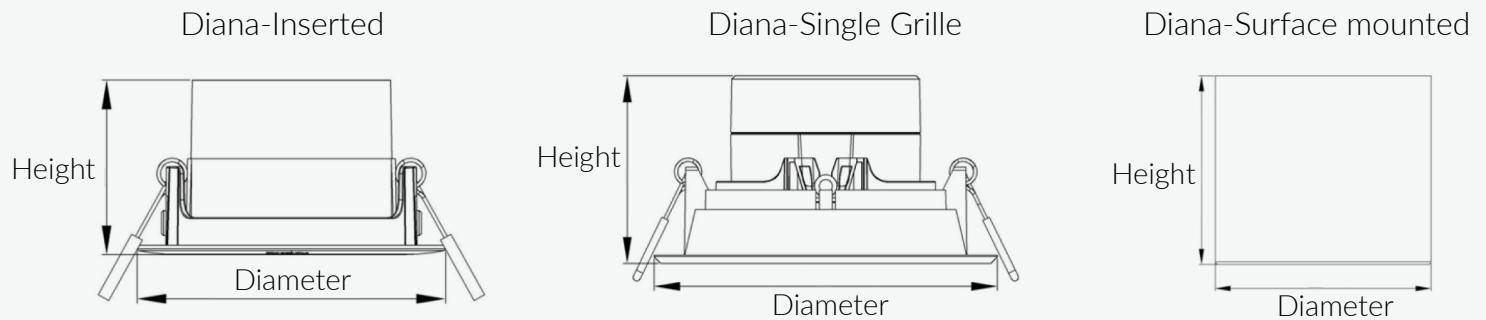

Type	Height	Diameter
Diana-Inserted	1.77Inch(45mm)	3.34Inch(85mm)
Diana-Single Grille	2.36Inch(60mm)	4.13Inch(105mm)
Diana-Surface mounted	3.85Inch(98mm)	2.52Inch(64mm)

**Technical Data:**

<b>Lamp Type</b>	Diana-Inserted	Diana-Single Grille	Diana-Surface mounted
<b>Input Voltage</b>	220-240V		
<b>Rated Power</b>	4.8W		
<b>Declared Luminous Flux</b>	Useful 350lm		
<b>Color Temperature</b>	3000K/6500K		
<b>Average Ra</b>	90		
<b>Beam Angle</b>	15°/24°/36°		
<b>Average Life</b>	25000H		
<b>Working Temperature</b>	-10 C (14 F) ~ 40 C (+104 F)		
<b>Material</b>	Plastic		Plastic, Matel
<b>Weight</b>	73g	105g	190g
<b>Environment</b>	IP20		
<b>Certificate</b>	CE/CB/ERP		