

UFO Highbay



0-10V Dimming



IK65



IK08

CE CB

Introduce:

The Topstar's UFO high bay light follows the high quality and high performance requirements of commercial and industrial lamps. It uses ultra-bright lamp beads to provide you with 150 lumens per watt of bright lighting, so that there is nowhere to hide in the darkness of your shop, garage, and barn. Die-cast aluminum shell coated with polyester powders with high resistance to harsh outdoor environment. The lens can be quickly replaced to obtain different beam angles and meet the optical design requirements of different projects. One model in stock means 3 solutions in hand.

Features & Benefits:

- 3 beam angle selectable: 60°, 90°, 120°
- 3 power selectable: 100W, 150W, 200W
- Ultra-high light efficiency up to 150 Lm/W
- Surge protection: 4KV
- Lifespan 69,000hrs-L80 B50, 111,000hrs-L70 B50
- Multiple mounting options: Suspend mounting (single point hook) 、 Surface mounting
- IK10 rated for maximum impact resistance
- IP65 protection against dust, moisture and environmental contaminants

Application place:

Warehouses / Storages / Industrial Facilities / Sports Facilities / Manufacturing Facilities / Gymnasiums / Airports / Retail Centers so on.

Available Sizes:

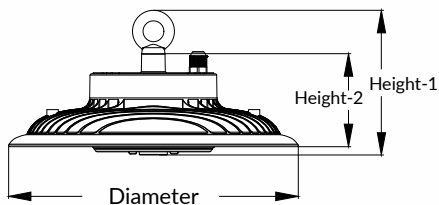

Model	Diameter	Height-1	Height-2
D260	260mm	129mm	76mm
D290	290mm	129mm	76mm
D328	328mm	129mm	76mm

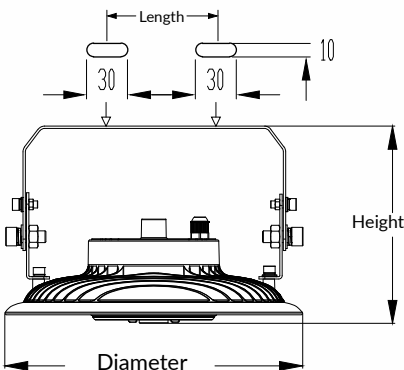

Model	Diameter	Height	Length
D260	260mm	178mm	80mm
D290	290mm	186mm	80mm
D328	328mm	188mm	125mm

Technical Data:

Type	UFO High bay D260	UFO High bay D290	UFO High bay D328
Rated Voltage	120-277V		
Rated Power	100W	150W	200W
Power Factor	PF0.95		
Declared Luminous Flux	15000lm	22500lm	30000lm
Energy efficiency	150lm/w		
Color Temperature	4000K/5000K		
Average Ra	Ra80		
Beam Angle	60°, 90°, 120°		
Average Life	69,000hrs-L80, 111,000hrs-L70		
Working Temperature	-20°C to +45°C		
Material	Aluminum Alloy\Polycarbonate Optical Lens		
Dimmable	0-10V Dimming		
Gross Weight (±0.3kg)	2.1kg	2.5kg	3.0kg
Environment	IP65	IP65	IP65
Certificate	CE/CB		